

Werkzeugkatalog

tool catalogue

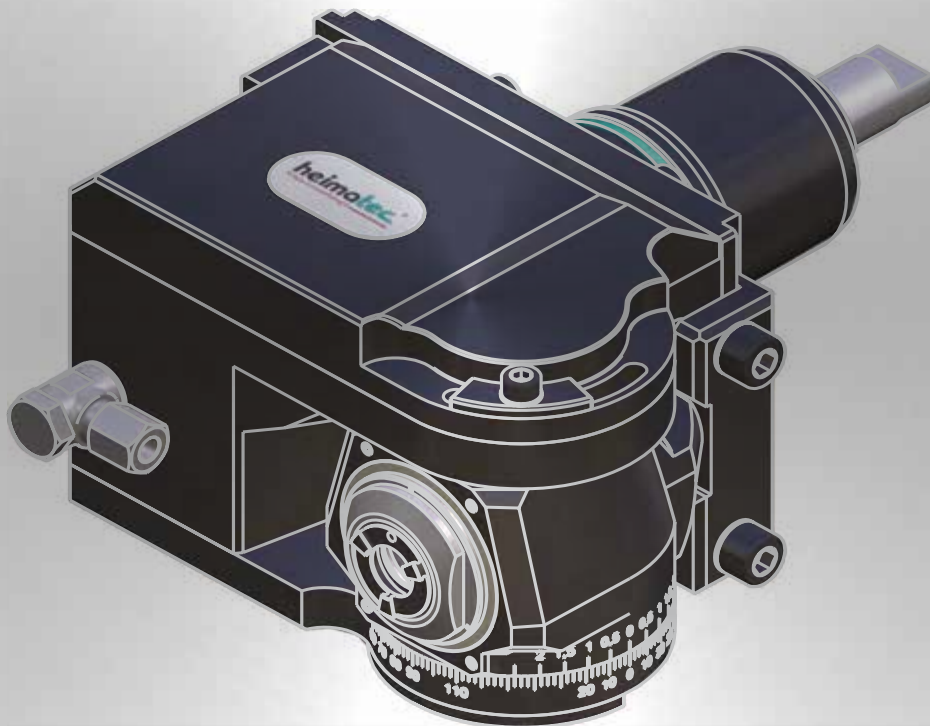

Mori Seiki

NL/NLX 1500 MC/Y/SMC/SY

NL/NLX 2000 MC/Y/SMC/SY

20 Werkzeugplätze / tool places



Hinweis zu den AGBs:

Diese finden Sie in unserem Internetauftritt unter

www.heimatec.de

Home/Impressum/AGB

Terms and conditions:

You will find them on our website

www.heimatec.com

Home/Imprint/Terms and Conditions

Das Katalog-Werk einschließlich aller seiner Teile ist urheberrechtlich geschützt. Jede Verwertung außerhalb der engen Grenzen des Urheberrechtsgesetzes ist ohne Zustimmung der Rechteeinhaber unzulässig und strafbar. Das gilt insbesondere für Vervielfältigungen, Übersetzungen, Mikroverfilmungen und die Einspeicherung und Verarbeitung in elektronischen Systemen.

heimatec® GmbH behält sich Änderungen technischer Art jederzeit ohne Vorankündigung vor. Dies gilt insbesondere bei Anpassungen an neue oder geänderte internationale Normen oder bei Weiterentwicklungen unserer Produkte oder Herstellungsprozesse.

This catalogue, including all its parts, is protected by copyright. Each use outside the restricted limitations of the Copyright Act is inadmissible and liable to prosecution without the consent of heimatec. This is particularly valid for duplication, translation, microfilming and feeding and processing in electronic systems.

heimatec® GmbH reserves the right of technical changes everytime without advance notice, which is particularly valid for adaptations to new or changed international standards, or to developments of our products or manufacturing processes.

angetriebene Werkzeuge
driven tools



Axial-Bohr- und Fräskopf
axial drilling and milling head

$n_{max} = 6000 \text{ min}^{-1}$

8 010 45 067	ER 25 AX u-tec	EK	1:1
8 010 45 068	ER 25 AX u-tec	IK 25 bar	1:1
8 010 45 098	ER 25 AX u-tec	IK 70 bar	1:1
8 010 46 171	ER 32 AX u-tec	EK	1:1
8 010 46 180	ER 32 AX u-tec	IK 25 bar	1:1
8 010 46 158	ER 32 AX u-tec	IK 70 bar	1:1
8 010 46 130	easy quick HT 4	EK	1:1
8 010 46 131	easy quick HT 4	IK 25 bar	1:1
8 010 46 168	easy quick HT 4	IK 70 bar	1:1



Axial-Bohr- und Fräskopf
axial drilling and milling head

$n_{max} = 12000 \text{ min}^{-1}$

8 010 45 104	ER 25 AX u-tec	EK	1:1
--------------	----------------	----	-----



Axial-Bohr- und Fräskopf
axial drilling and milling head

$n_{max} = 24000 \text{ min}^{-1}$

8 013 44 009	ER 16 AX u-tec	EK	1:4
8 013 44 010	ER 16 AX u-tec	IK 70 bar	1:4



Axial-Bohr- und Fräskopf
axial drilling and milling head

$n_{max} = 6000 \text{ min}^{-1}$

8 011 44 024	Kombidorn/universal arbor 16	EK	1:1
8 011 45 022	Kombidorn/universal arbor 22	EK	1:1
8 011 44 025	Kombidorn/universal arbor 3/4"	EK	1:1
8 011 45 030	Kombidorn/universal arbor 1/2"	EK	1:1



Axial-Bohr- und Fräskopf
axial drilling and milling head

Achsversatz / offset A=50
 $n_{max} = 12000 \text{ min}^{-1}$

8 019 45 138	ER 25 AX u-tec	IK 140 bar	1:1
--------------	----------------	------------	-----



Axial-Bohr- und Fräskopf
axial drilling and milling head

Achsversatz / offset A=50

8 019 45 085	ER 25 AX u-tec	EK	1:1
8 019 45 086	ER 25 AX u-tec	IK 140 bar	1:1
$n_{max} = 6000 \text{ min}^{-1}$			
8 019 46 076	easy quick HT 4	EK	1:1
8 019 46 077	easy quick HT 4	IK 140 bar	1:1
$n_{max} = 6000 \text{ min}^{-1}$			
8 019 44 069	ER 20 AX u-tec	EK	1:2
8 019 44 070	ER 20 AX u-tec	IK 140 bar	1:2
$n_{max} = 12000 \text{ min}^{-1}$			
8 019 44 071	ER 16 AX u-tec	EK	1:3
8 019 44 049	ER 16 AX u-tec	IK 140 bar	1:3
$n_{max} = 18000 \text{ min}^{-1}$			
8 019 45 136	ER 25 AX u-tec	EK	2:1
8 019 45 137	ER 25 AX u-tec	IK 140 bar	2:1
$n_{max} = 3000 \text{ min}^{-1}$			



Winkel-Bohr- und Fräskopf radial drilling and milling head

Mittenmaß / center distance H=85
 $n_{max} = 6000 \text{ min}^{-1}$

8 030 45 139	ER 25 AX u-tec	EK	1:1
8 030 45 140	ER 25 AX u-tec	IK 140 bar	1:1
8 030 46 316	ER 32 AX u-tec	EK	1:1
8 030 46 320	ER 32 AX u-tec	IK 140 bar	1:1
8 030 46 232	easy quick HT 4	EK	1:1
8 030 46 233	easy quick HT 4	IK 140 bar	1:1



Winkel-Bohr- und Fräskopf radial drilling and milling head

Mittenmaß / center distance H=85
 $n_{max} = 12000 \text{ min}^{-1}$

8 030 45 195	ER 25 AX u-tec	EK	1:2
8 030 45 235	ER 25 AX u-tec	IK 140 bar	1:2
8 030 46 352	easy quick HT 4	EK	1:2
8 030 46 398	easy quick HT 4	IK 140 bar	1:2



Winkel-Bohr- und Fräskopf radial drilling and milling head

Mittenmaß / center distance H=85
 $n_{max} = 18000 \text{ min}^{-1}$

8 030 45 236	ER 25 AX u-tec	EK	1:3
8 030 45 237	ER 25 AX u-tec	IK 140 bar	1:3
8 030 46 399	easy quick HT 4	EK	1:3
8 030 46 400	easy quick HT 4	IK 140 bar	1:3



Winkel-Bohr- und Fräskopf radial drilling and milling head

Mittenmaß / center distance H=85
 $n_{max} = 24000 \text{ min}^{-1}$

8 030 44 079	ER 16 AX u-tec	EK	1:4
8 030 44 080	ER 16 AX u-tec	IK 140 bar	1:4



Winkel-Bohr- und Fräskopf radial drilling and milling head

Mittenmaß / center distance H=85
 $n_{max} = 12000 \text{ min}^{-1}$

8 030 45 202	ER 25 AX u-tec	EK	1:2
8 030 45 206	ER 25 AX u-tec	IK 140 bar	1:2



Winkel-Bohr- und Fräskopf radial drilling and milling head

Mittenmaß / center distance H=85
 $n_{max} = 6000 \text{ min}^{-1}$

8 031 44 036	Kombidorn/universal arbor 16	EK	1:1
8 031 45 027	Kombidorn/universal arbor 22	EK	1:1
8 031 44 037	Kombidorn/universal arbor 3/4"	EK	1:1
8 031 45 045	Kombidorn/universal arbor 1"	EK	1:1



Winkel-Bohr- und Fräskopf radial drilling and milling head

Mittenmaß / center distance H=85
 $n_{max} = 6000 \text{ min}^{-1}$
doppelspindel / double spindle

8 039 45 030	ER 25 AX u-tec	EK	1:1
8 039 46 029	easy quick HT 4	EK	1:1

► Weitere Ausführungen auf Anfrage
further versions on request

► Zubehör ZB...*
accessories ZB...*



► easy-quick



► u-tec





**Schwenkkopf
universal head**

8 043 44 009	ER 16 AX u-tec	EK	1:1
8 043 44 008	ER 16 AX u-tec	IK 25 bar	1:1
<i>n_{max} = 6000 min⁻¹</i>			
8 043 44 022	ER 16 AX u-tec	EK	1:2
8 043 44 023	ER 16 AX u-tec	IK 25 bar	1:2
<i>n_{max} = 12000 min⁻¹</i>			



**Axial-Mehrspindel Werkzeuge
axial multi spindle tools** **2-spindlig
2-spindles**

*Achsversatz / offset A=30
n_{max} = 6000 min⁻¹*

8 050 44 025	ER 16 AX u-tec	EK	1:1
8 050 44 026	ER 16 AX u-tec	IK 140 bar	1:1



**Winkel-Mehrspindel Werkzeuge
angel multi spindle tools** **3-spindlig
3-spindles**

*Mittenmaß / center distance H=85
Achsversatz / offset A=30
n_{max} = 6000 min⁻¹*

8 053 44 015	ER 16 AX u-tec	EK	1:1
8 053 44 016	ER 16 AX u-tec	IK 140 bar	1:1

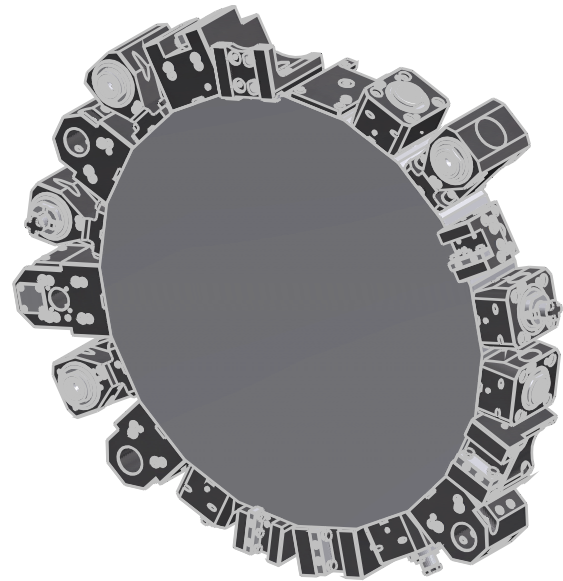

**feste Werkzeuge
static tool holders**



**Kombi-Drehstahlhalter
universal turning holder** **kurze Ausführung
short version**

8 224 14 003	Vierkant/square 20	EK
8 224 15 007	Vierkant/square 25	EK
8 224 14 005	Vierkant/square 3/4"	EK
8 224 15 017	Vierkant/square 1"	EK



**Kombi-Drehstahlhalter
universal turning holder** **lange Ausführung
long version**

8 224 14 009	Vierkant/square 20	EK
8 224 14 010	Vierkant/square 3/4"	EK



**Kombi-Doppel- Drehstahlhalter
combi double turning holder** **kurze Ausführung
short version**

8 251 14 015	Vierkant/square 20	EK
8 251 15 011	Vierkant/square 25	EK
8 251 14 024	Vierkant/square 3/4"	EK
8 251 15 012	Vierkant/square 1"	EK

Mori Seiki NL/NLX 1500 - 2000 MC/Y/SMC/SY

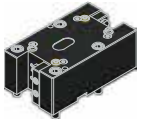

Kombi-Doppel- Drehstahlhalter lange Ausführung
combi double turning holder long version

8 251 14 025	Vierkant/square 20	EK
8 251 14 026	Vierkant/square 3/4"	EK



Kombi- Plandrehhalter
combi facing holder

8 244 14 003	Vierkant/square 20	EK
8 244 15 003	Vierkant/square 25	EK
8 244 14 004	Vierkant/square 3/4"	EK
8 244 15 007	Vierkant/square 1"	EK



Bohrstangenhalter
boring bar holder

Mittenmaß / center distance H=100

8 240 18 032	ø32	IK/EK
8 240 19 034	ø40	IK/EK
8 240 18 042	ø1 1/4"	IK/EK
8 240 19 064	ø1 1/2"	IK/EK



Doppel- Bohrstangenhalter
double boring bar holder

Mittenmaß / center distance H=75/105

8 253 17 049	ø25	IK/EK
8 253 17 054	ø1"	IK/EK



Abstechhalter
cut-off holder

8 224 12 019	SH 26	EK
--------------	--------------	----



Abdeckplatte
cover plate

8 200 41 006		
--------------	--	--



▶ Weitere Ausführungen auf Anfrage
further versions on request

▶ Zubehör ZB...*
accessories ZB...*



▶ easy-quick



▶ u-tec



Hauptsitz/headquarters

heimatec® GmbH
Präzisionswerkzeuge
Carl-Benz-Straße 4
D- 77871 Renchen
Postfach 11 36
D- 77867 Renchen
Tel.: +49 (78 43) 94 66 0
Fax: +49 (78 43) 94 66 66
www.heimatec.de
info@heimatec.de

heimatec® Inc.
16 E. Piper Lane Suite 121
USA- 60070 Prospect Heights IL
Tel.: +1 (847) 749 0633
Fax: +1 (847) 749 2445
www.heimatecinc.com
info@heimatecinc.com

heimatec® - Ost, JSC
ul. Kozjubinskogo 4 ofice 209
RUS- 121351 Moskau
Tel.: +7 (495) 648 69 19
Fax: +7 (495) 648 69 19
www.heimatec-ost.ru
sales@heimatec-ost.ru

